

The OEM module 3.0 is a powerful, easy to integrate distance measuring module. Due to safety aspects (e.g. laser safety, labeling, ...), system integration is limited to companies which are qualified to integrate such modules into their own housing and/or complete system.

Therefore this module is not intended to be sold as a final product or for any purposes other than the above-mentioned.



Type: OEM module 3.0 WH15

Type: OEM module 3.0 WH30



Contents:

1. TECHNICAL DATA	3
2. PHYSICAL DIMENSIONS AND FIXING	4
3. INTERFACE PARAMETERS	5
3.1. SOFTWARE PARAMETERS	5
3.2. PIN ASSIGNMENT OF THE D-SUB CONNECTOR	5
4. POWER ON /OFF	6
5. SOFTWARE INTERFACE PROTOCOL	6
5.1. GENERAL DEFINITIONS	6
5.1.1. Characters	6
5.1.2. Entries	6
5.1.3. Replies	6
5.2. DATA FORMAT	7
5.3. WORD INDEXES (WI)	7
5.4. ERROR REPORTS	8
6. COMMANDS	9
6.1. GENERAL	9
6.2. SET OF COMMANDS	9
6.2.1. RESET command (a)	9
6.2.2. OFF command (b)	9
6.2.3. STOP/CLEAR command (c)	9
6.2.4. Distance measurement (g)	9
6.2.5. Distance measurement (G)	9
6.2.6. Tracking (h)	9
6.2.7. Tracking (H)	10
6.2.8. Signal measurement (k)	10
6.2.9. Temperature measurement (t)	10
6.2.10. Laser (o, p)	10
6.2.11. Software version (00)	10
6.2.12. Hardware version (01)	10
6.2.13. Serial number (02)	10
6.2.14. Date of manufacture (03)	10
6.2.15. Setting distance offset (44)	10
6.2.16. Setting baud rate (70)	11
7. MEASURING ACCURACY	11
8. ACCESSORIES	11
9. VALIDITY	12

1. Technical data

Typical measuring accuracy for WH15 ¹⁾	+/- 1.5 mm
Typical measuring accuracy for WH30 ¹⁾	+/- 3 mm
Maximum measuring accuracy for WH15 ¹⁾	+/- 2 mm
Maximum measuring accuracy for WH30 ¹⁾	+/- 5 mm
Smallest unit displayed	0.1 mm
Measuring range on natural surfaces	0.3 to 30 m
Measuring range on brown (reflecting) target plate	ca. 20 to 100 m
Unambiguous display	0 to 300 m
Measuring reference	from front edge (See 2 Physical dimensions and fixing on page 4)
Diameter of laser spot at target at a distance of:	10 m → 6 mm 50 m → 30 mm 100 m → 60 mm
Time for a measurement: Single measurement	0.6 to ca. 5 sec
Tracking	0.15 to 5sec
Vibration	10 to 50 Hz, +/- 0.15 mm, 5 cycles 1 octave / min (at maximum and minimum operating temperature) ISO 9022-36-05
Bump (Shock)	25 g, 6 ms, 4000 shocks each axis and direction ISO 9022-31-06
Drop	500g single shock once, on all surfaces
Light source	Laserdiode 620-690 nm (red) IEC 60825-1:1993; Class 2 FDA 21CFR Ch.I §1040: 1988; Class II Beam divergence: 0.16 x 0.6 mrad Pulse duration: 15x10 ⁻⁹ s Maximum radiant power: 0.95 mW Maximum radiant power per pulse: 8mW Measurement uncertainty: ±5%
ESD (Without cables)	(IEC 61000-4-2 (1995-01) Level 1) 2kV tested on metal body
EMC (Without cables)	IEC 61000-4-3 (1995-02) EN55022 Klasse B 1994 FCC Part 15 Class B
Power supply	DC 9V ... 30V
ON	max. 250mA
OFF	27mA @ 10V
Dimensions	140 x 70 x 55 mm
Temperature range	-10 °C to +50 °C ²⁾
Operation	
Storage	-40 °C to +70 °C
Degree of Protection	IP65; IEC60529 (protected against ingress of dust and water)
Weight	430 g
Interface	Serial asynchronous interface (RS232 and RS422)

¹⁾ See 7 Measuring accuracy on page 11

²⁾ In case of permanent measurement (tracking mode) the max. temperature is reduced to 45°C



2. Physical dimensions and fixing

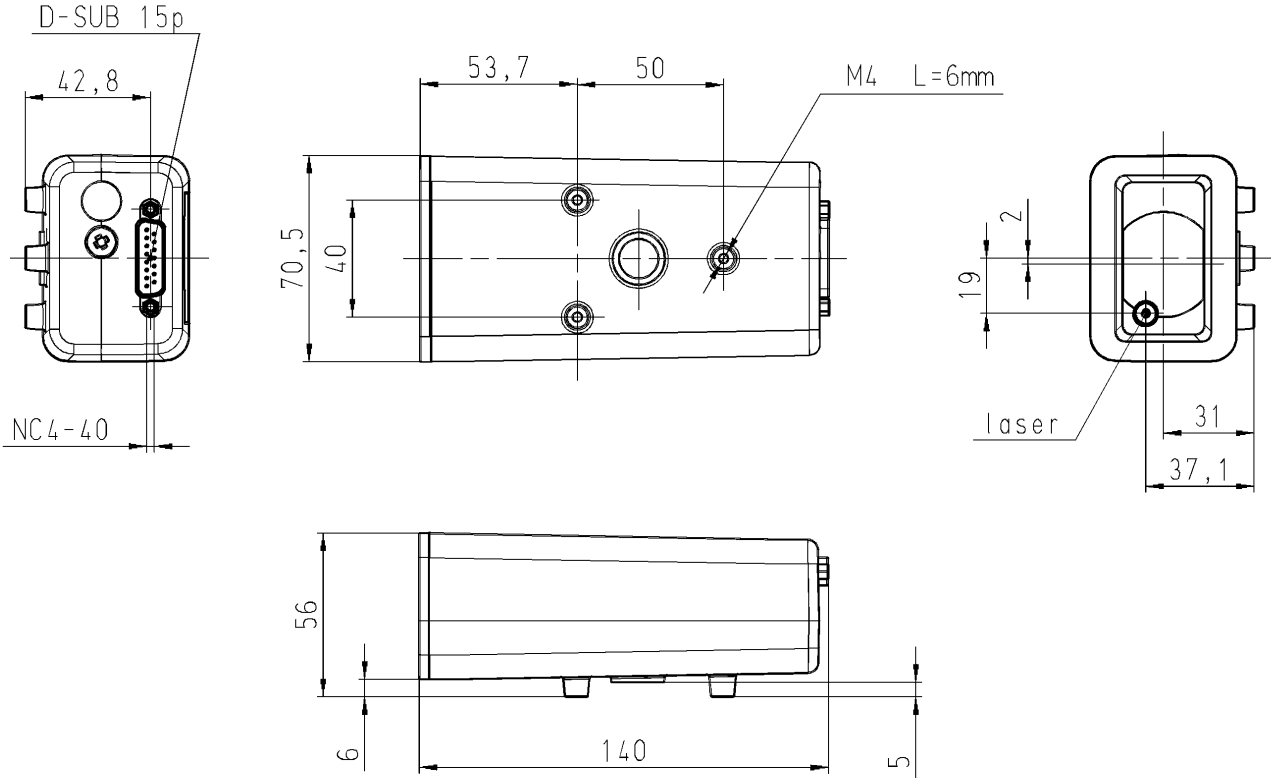

	<p>When fixing the Module you have to be careful not to point the instrument directly toward the sun. The telescope functions as a magnifying lens and such exposure can damage the distance measuring device.</p>
	<p>You have to ensure, that the optics are kept free from dust, dirt and water.</p> <p>Clean and Dry:</p> <ul style="list-style-type: none"> Blow away dust from lenses. Do not touch the optics with fingers. Only clean with a soft cloth; if necessary, dampen with pure alcohol. Do not use other cleaning agents. Plastic parts could be affected.
	<p>Please note the laser beam is not parallel to the housing or to the fixing points.</p>

3. Interface parameters

3.1. Software parameters

The interface of the OEM module 3.0 has been arranged so that it can be connected to a PC by means of an adapter. The parameters of the interface are defined ex-works as follows:

9600 baud, none parity, 8 data bits, 1 stop bit

These settings can be changed, using the interface commands.

3.2. Pin assignment of the D-sub connector

The 15 pin D-sub connector contains the lines for RS232, RS422 and the power.

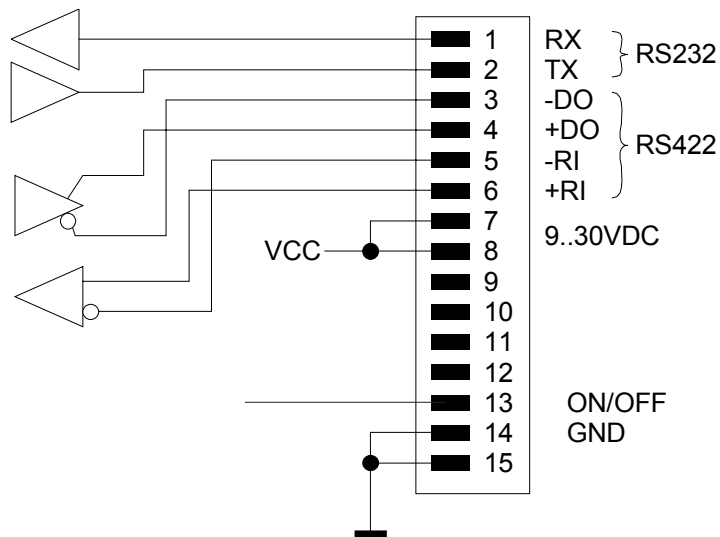

Pin	Designator	Description	Colors for accessories cable	
			RS422 Cable	RS232 Cable
1	RS232 Tx	RS232 Send line		White
2	RS232 Rx	RS232 Receive line		Brown
3	-DO	RS422 Send line negative	White	
4	+DO	RS422 Send line positive	Brown	
5	-RO	RS422 Receive line negative	Green	
6	+RO	RS422 Receive line positive	Yellow	
7	BAT +	Power DC +9V...+30V	Brown (Supply cable)	
8	BAT +	Power DC +9V...+30V		
9	NC			
10	NC			
11	NC			
12	NC			
13	ON / OFF	ON: Open OFF: switch to ground	Green (Supply cable)	
14	GND	Ground line	Grey	Green
15	GND	Ground line	White (Supply cable)	

4. Power on /off

- **Pin 13 of the D-sub Connector is Open (Tristate):**
To switch the module on, use command “a” (See 6.2.1 RESET command (a) on page 9).
To switch the module off, use the command “b” (See 6.2.2 OFF command (b) on page 9). After this command, the measurement module is switched off, but the electronic interface is still active and waits for the next command on the serial interface.
- **Pin 13 of the D-sub Connector is switched to ground:**
The module and the interface board are switched off. All commands are ignored.

5. Software interface protocol

5.1. General definitions

5.1.1. Characters

All characters with ASCII codes below 127 can be used for entering commands. A command is concluded by means of an ASCII code below 32 (last character or terminator <trm>).

The *OEM module 3.0* also transmits a terminator to conclude a reply. The terminator transmitted is <cr><lf>.

5.1.2. Entries

Each *OEM module 02* command consists of one or more letters and a terminator.

Examples:

```
a<trm>
NOON<trm>
```

Numerical entries (command parameters, %) are always entered as whole numbers and the following format is permitted:

Sign (optional) and digits which do not commence with zero: -8007.

5.1.3. Replies

OEM module 3.0 transmits one or more replies to each command received. These are the possible replies:

?<trm>	- OK prompt: Everything ok, <i>OEM module 3.0</i> is ready to execute a new command
@E123<trm>	- Error report: A three-digit error code is transmitted in accordance with the table in the appendix.
12..10+12345678 <trm>	- One or more data words with terminator.
Plain text	- Plain-text data

A command will result in at least an OK prompt or an error report.

5.2. Data format

A data word as reply consists of 16 characters, combined as follows:

1	2	3	4	5	6	7	8	9	10	11	12	13	14	15	16
W	W	+	1	2	3	4	5	6	7	8	

Position	Description:	Remark
1,2	Word index 00-99	With zeroes at start
3,4	no significance	In service mode as expansion of word index
5	Attribute	0: Measured value 1: Manually-entered value
6	Units	0: mm . : No units
7-15	Decimal value	With sign and zeroes at start
16	Space	

In some instances the following data format appears:

1	2	3	4	5	6	7	8	9	10	11	12	13	14	15	16
W	W	+	1	2	3	4	+	6	7	8	

Position	Description:	Remark
1,2	Word index 00-99	With zeroes at start
3,4	no significance	In service mode as expansion of word index
5	Attribute	0: Measured value 1: Manually-entered value . : No attribute set
6	Units	0: mm . : No units
7-11	Decimal value 1	With sign and zeroes at start
12-15	Decimal value 2	With sign and zeroes at start
16	Space	

5.3. Word indexes (WI)

The following WIs are available to the user:

WI no.	Format (example)	Meaning	Rem.
12	12....+xxxxxxxx	Serial number of module [0....99999999]	
13	13....+xxxxyyyy	Software version xxxx: Identification yyyy: SW-Version 0100 -> V1.00	
14	14....+xxxxxyy	Hardware version xxxxxx: Board number yy: Revision index	
15	15....+xxxxxxxx	Date of manufacture [YYYYMMDD] Year, Month, Day	
31	31..06+xxxxxxxx	Slope distance [1/10 mm]	
40	40....+xxxxxxxx	Temperature [1/10 ° C]	
51	51....+xxxxxxxx	Always 0 (only for compatibility reasons)	
53	53....+xxxxxxxx	Measurement signal [mV]	
58	58..16+xxxxxxxx	Distance offset [1/10 mm]	

5.4. Error reports

No.	Format	Meaning
203	@E203	Prohibited parameter in command entry, or prohibited command, or non-valid result
217	@E217	Parameter set-up incorrect (Contact Dimetix)
221	@E221	Parity error (Prior to contacting Dimetix please check the Terminal settings)
222	@E222	Interface buffer overflow (Contact Dimetix if error occurs when sending less than 24 characters)
223	@E223	Interface framing error (Contact Dimetix)
224	@E224	GSI buffer overflow (Contact Dimetix if error occurs when sending less than 24 characters)
252	@E252	Temperature too high (contact Dimetix if error occurs at room temperature)
253	@E253	Temperature too low (contact Dimetix if error occurs at room temperature)
255	@E255	Received signal too weak, distance < 250mm (Use different target and distances, if the problem persists, please contact Dimetix)
256	@E256	Received signal too strong (Use different target and distances, if the problem persists, please contact Dimetix)
257	@E257	Too much background light (Use different target and distances, if the problem persists, please contact Dimetix)
272 to 299	@E272	Hardware failure (Contact Dimetix)

Before contacting Dimetix please collect as much information as possible.

6. Commands

6.1. General

After a command has been entered, it is decoded and processed. If additional commands are sent, processing of the current command will be aborted if possible and the last command to be received will be processed. After the command has been executed, there will always be either an OK prompt or an error report.

6.2. Set of commands

6.2.1. RESET command (a)

Function: Resets the module.
 GSI IN: a<trm>
 GSI OUT: ?<trm> or @Exxx<trm>

6.2.2. OFF command (b)

Function: Switches the module off. It is very important to switch the module off, before disconnecting the power. To switch the module on, use pin 2 at connector J1 (See 3.2 Pin assignment on page 5).
 GSI IN: b<trm>
 GSI OUT: ?<trm> or @Exxx<trm>

6.2.3. STOP/CLEAR command (c)

Function: Stops the current execution.
 GSI IN: c<trm>
 GSI OUT: ?<trm> or @Exxx<trm>

6.2.4. Distance measurement (g)

Function: Triggers simple measurement of distance. Each new command cancels an active measurement.
 GSI IN: g<trm>
 GSI OUT: WI31 WI51<trm> or @Exxx<trm>

6.2.5. Distance measurement (G)

Function: Triggers configurable measurement of distance. (not implemented in the current SW version, react like the command g)
 GSI IN: G<trm>
 GSI OUT: WI31<trm> or @Exxx<trm>

6.2.6. Tracking (h)

Function: Triggers continuous measurement of distance. The measurements are continued until the next command is issued or until a fault arises.
 GSI IN: h<trm>
 GSI OUT: WI31 WI51<trm> or @Exxx<trm>

6.2.7. Tracking (H)

Function: Triggers continuous measurement of distance. The measurements are continued until the next command is issued or until a fault arises.
 GSI IN: H<trm>
 GSI OUT: WI31<trm> or @Exxx<trm>

6.2.8. Signal measurement (k)

Function: Triggers continuous measurement of the signal. The measurements are continued until the next command is received or until a fault arises.
 GSI IN: k<trm>
 GSI OUT: WI53<trm> or @Exxx<trm>

6.2.9. Temperature measurement (t)

Function: Triggers measurement of temperature.
 GSI IN: t<trm>
 GSI OUT: WI40<trm> or @Exxx<trm>

6.2.10. Laser (o, p)

Function: Switches laser on or off.
 GSI IN: o<trm> Switches laser on
 p<trm> Switches laser off
 GSI OUT: ?<trm> or @Exxx<trm>

6.2.11. Software version (00)

Function: Outputs software version at interface.
 GSI IN: N00N<trm>
 GSI OUT: WI13<trm> or @Exxx<trm>

6.2.12. Hardware version (01)

Function: Outputs instrument type at interface.
 GSI IN: N01N<trm>
 GSI OUT: WI14<trm> or @Exxx<trm>

6.2.13. Serial number (02)

Function: Outputs serial number at interface.
 GSI IN: N02N<trm>
 GSI OUT: WI12<trm> or @Exxx<trm>

6.2.14. Date of manufacture (03)

Function: Date of manufacture at interface.
 GSI IN: N03N<trm>
 GSI OUT: WI15<trm> or @Exxx<trm>

6.2.15. Setting distance offset (44)

Function: Sets distance offset. The offset is added to each distance measured. Setting is nonvolatile!
 GSI IN: N44N%N<trm>
 %: Distance offset [1/10mm] within the range $\pm 29.999\text{m}$
 GSI OUT: WI58<trm> or @Exxx<trm>

6.2.16. Setting baud rate (70)

Function: Sets the baud rate with fixed parity (none parity).

GSI IN: N70N%N<trm>

%	Baud rate	%	Baud rate
3	1200	6	9600
4	2400	7	19200
5	4800		

GSI OUT: ?<trm> or @Exxx<trm>

7. Measuring accuracy

The measuring accuracy corresponds to the ISO-recommendation ISO/R 1938-1971 with a statistical confidence level of 95% (i.e. ± twice the standard deviation, refer to diagram below). The typical measuring accuracy relates to average conditions for measuring. It is valid in the tracking mode.

The maximum measuring error relates to unfavorable conditions such as:

- highly-reflecting surfaces (e.g. reflector tapes)
- operating at the limits of the permitted temperature range, adaptation to ambient temperature interrupted
- very bright ambient conditions, strong heat shimmer

and can be up to ± 2 mm for WH15 and ± 5 mm for WH30 (twice standard deviation).

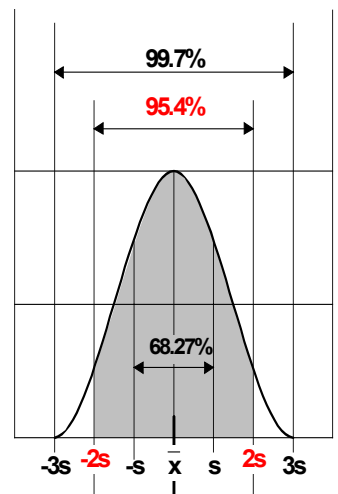

During the measuring time the distance will be averaged. This applies when measuring to moving targets.

8. Accessories

Interface Cable for RS232

IP65 protected cable for RS232 Interface and power supply (15 pin D-sub to 9 pin D-sub female connector and separate Power Supply). For colors and assignment refer to table under 3.2 Pin assignment of the D-sub connector.

Length 3m

Interface Cable for RS422

IP65 protected cable for RS422 Interface and power supply (15 pin D-sub to RS422 and separate Power Supply). For colors and assignment refer to table under 3.2 Pin assignment of the D-sub connector.

Length 3m

9. Validity

This document is valid for the OEM module 3.0. The following firmware versions support the listed commands:

Identification:	0000	(0000)
Version:	V2.00	(0200)
Version:	V2.20	(0220)
Version:	V3.20	(0320)

To get this information refer to *6.2.11 Software version (00)* on Page 10.



Dimetix AG
Degersheimerstr. 14
CH-9100 Herisau
Switzerland
Tel. + 41-71-353 00 00
Fax + 41-71-353 00 01
Email info@dimetix.com
Web www.dimetix.com